

ELEKTRA SYMBOLEN

	dubbele horizontale wandcontactdoos (wcd) woonkamer & slaapkamers 300+ vloer, overige ruimten 1050+ vloer
	dubbele wandcontactdoos (wcd)
	enkele wcd met randaarde
	enkele wcd t.b.v. afzuigkap 2250+vloer
	enkele wcd perilex elektrisch koken
	enkele wcd t.b.v. koelkast
	enkele wcd t.b.v. oven/magnetron
	enkele wcd t.b.v. radiator
	enkele wcd t.b.v. vaatwasser
	enkele wcd t.b.v. wasapparaat
	enkele wcd t.b.v. wasdroger
	combinatie enkele wcd met enkelpolige schakelaar
	3 standen schakelaar mechanische ventilatie
	thermostaat
	aansluitpunt boiler, loze leiding naar meterkast (mk)
	aansluitpunt telecommunicatie, 300+ vl., loze leiding naar mk

	enkelpolige schakelaar, 1050+ vloer
	wisselschakelaar, 1050+ vloer
	mechanische ventilatie draadloos
	aansluiting plafondlichtpunt (zonder armatuur)
	aansluiting wandlichtpunt (zonder armatuur)
	aansluiting wandlichtpunt (met armatuur)
	belinstallatie
	beldrukker
	optische rookmelder, aangesloten op elektriciteitsnet (NEN 2555)
	omvormer t.b.v. zonnepanelen
	hoofdaarding en aarding badkamer
	mechanische ventilatie aan-/afzuigpunt
	standleiding evt. i.c.m. ontluftung
	vloerverwarming verdeler
	elektrische radiator afmetingen door installateur
	vloerverwarming



Afkortingen

hwa	= hemelwaterafvoer
kk	= opstelplaats koelkast
mv	= mechanische ventilatie
R	= rookmelder volgens NEN 2555
stl	= standleiding riolering
vr	= ventilatierooster
vzv	= vloerverwarming verdeler
wm	= opstelplaats wasmachine
wd	= opstelplaats wasdroger
wp	= warmtepomp

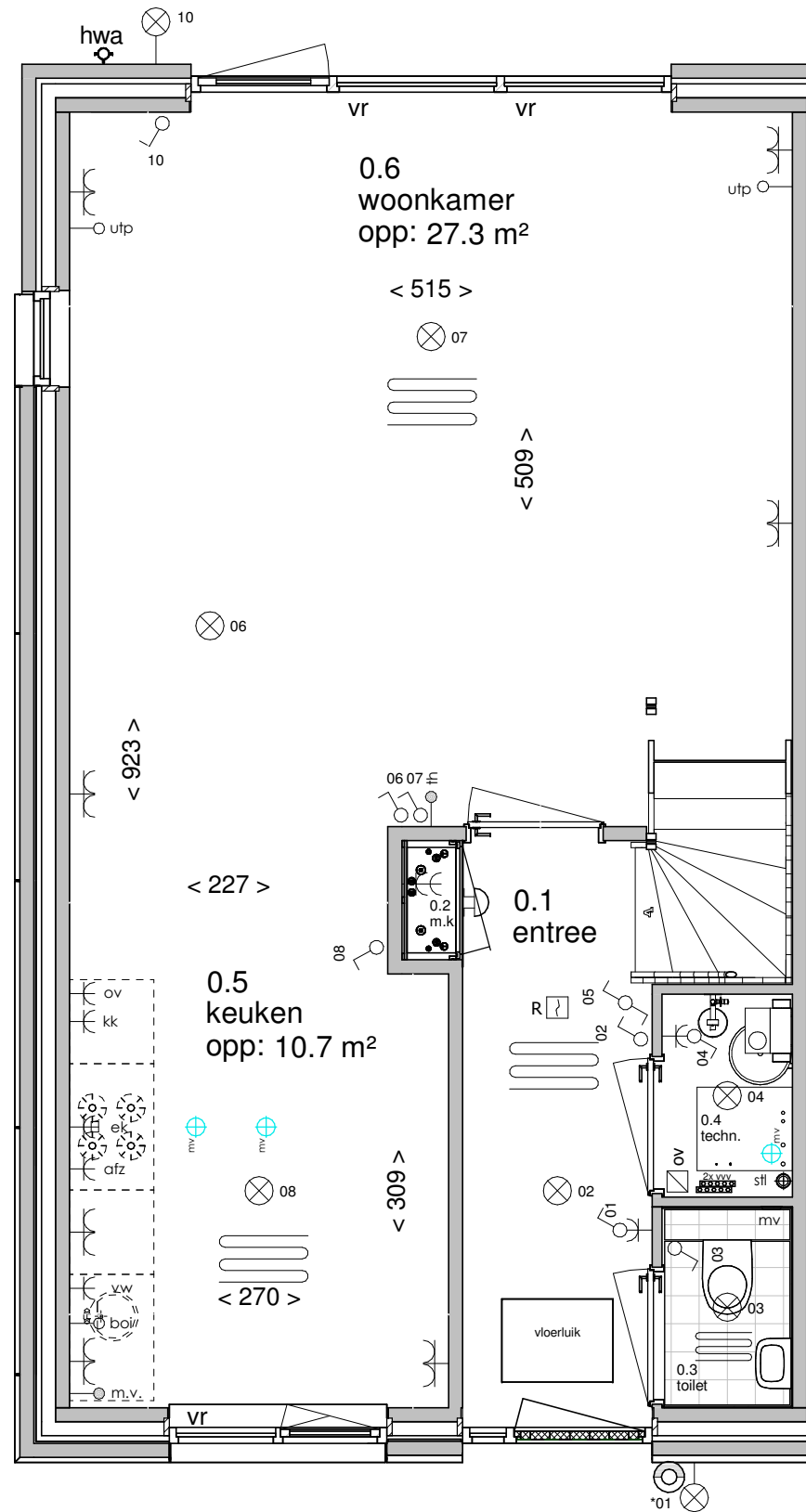

Begane grond

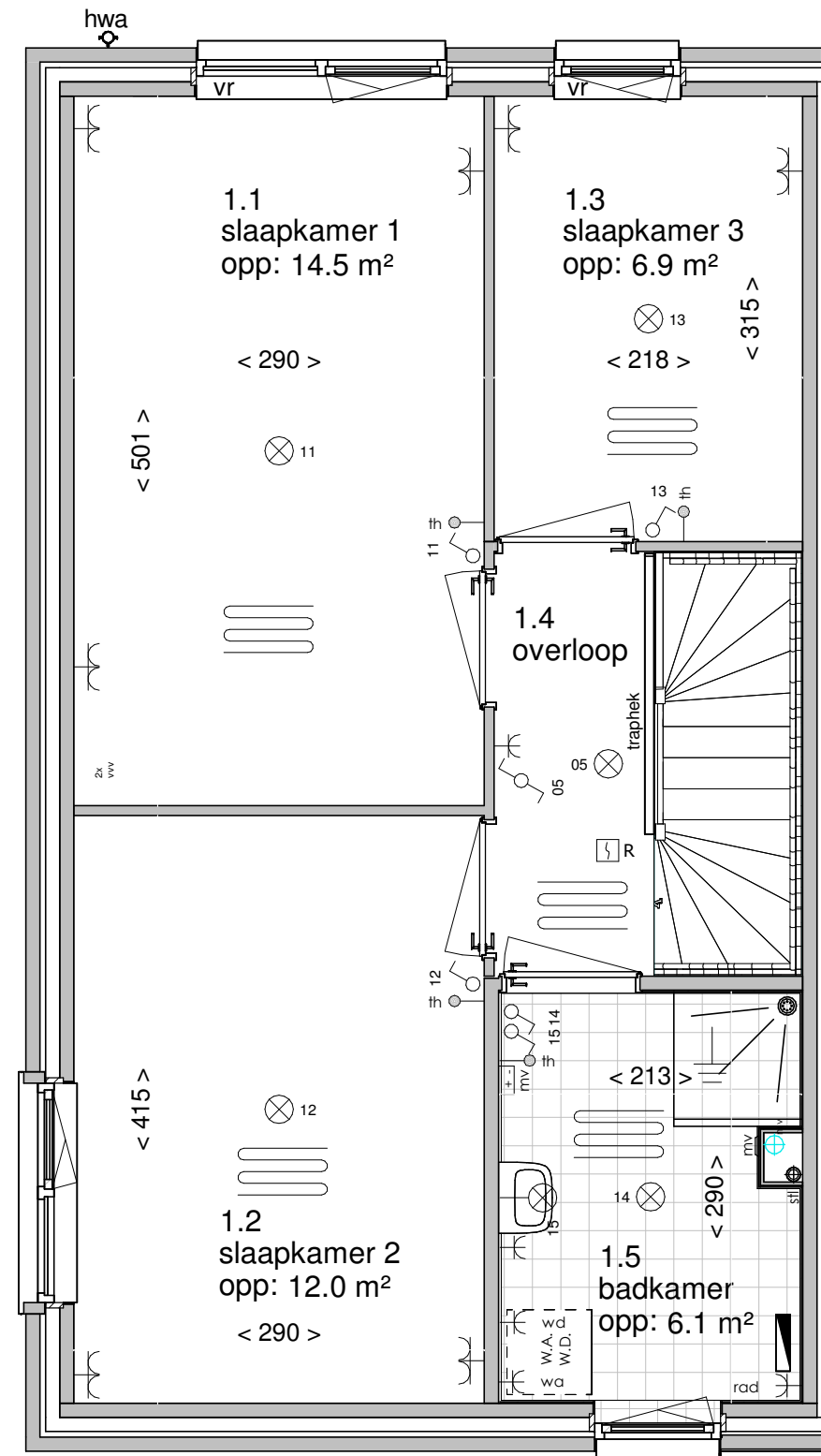

Eerste verdieping

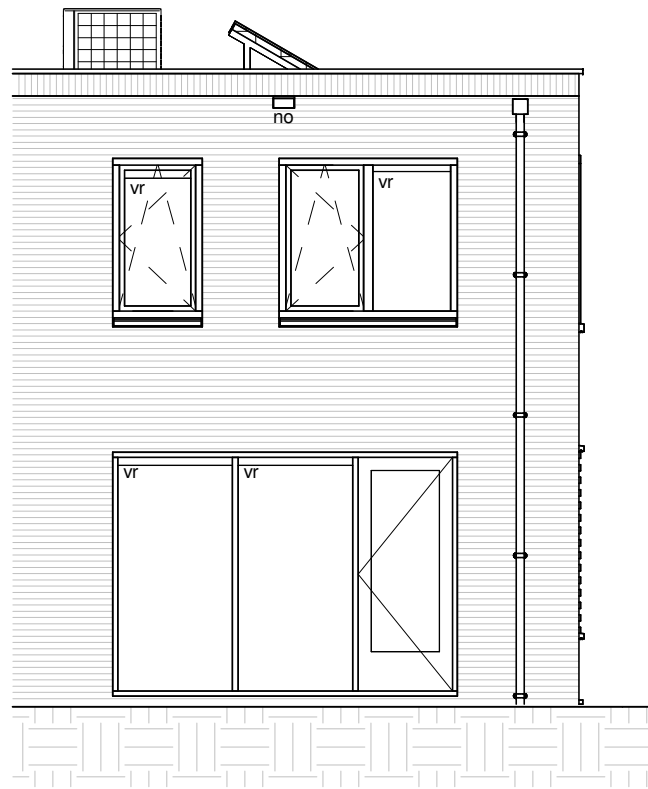

Achteraanzicht

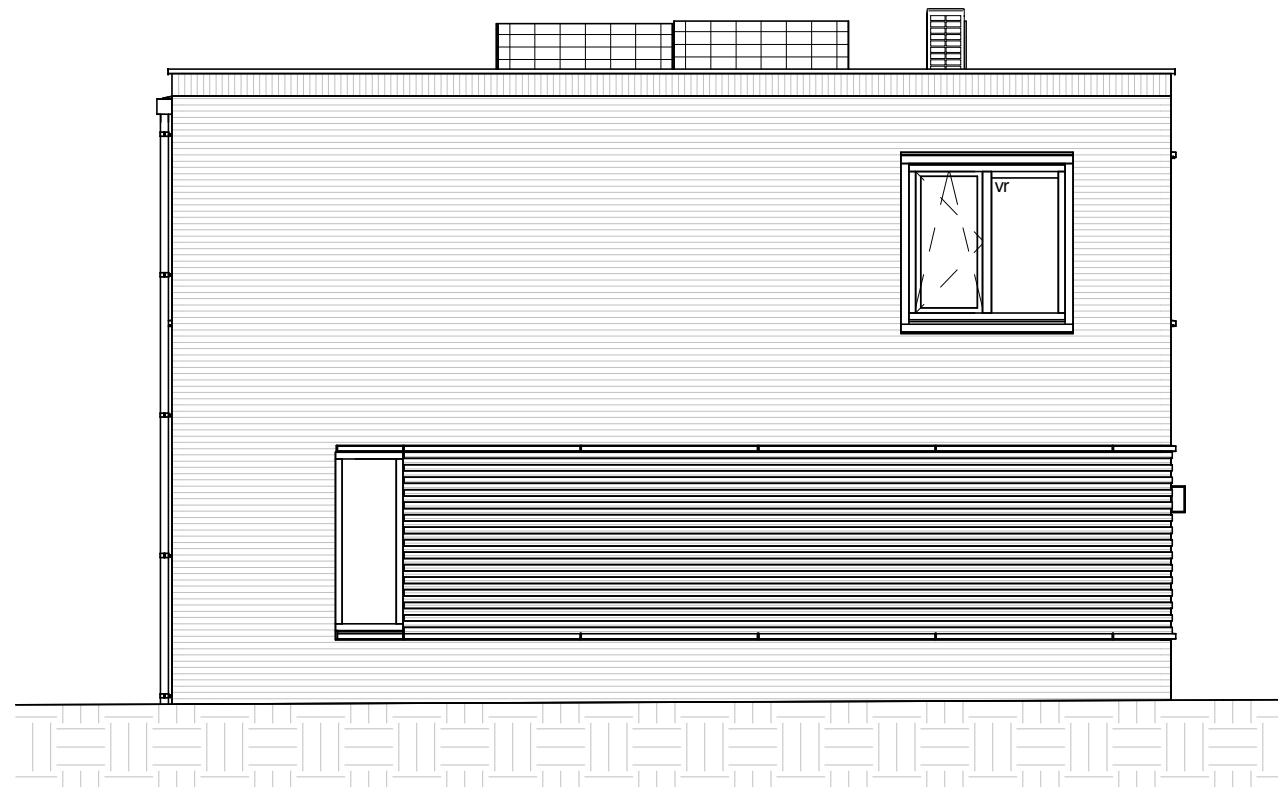

Linkerzij aanzicht



Voor aanzicht

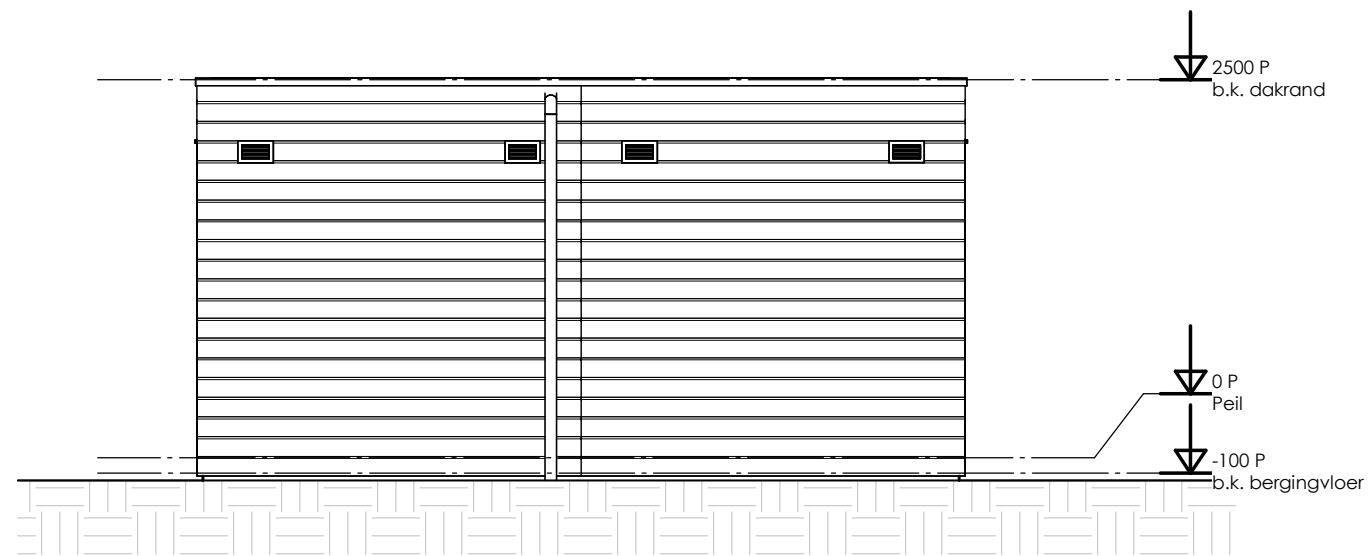

Bouwnummer 40-43-46-49
Vooraanzicht

Bouwnummer 41-44-45-48

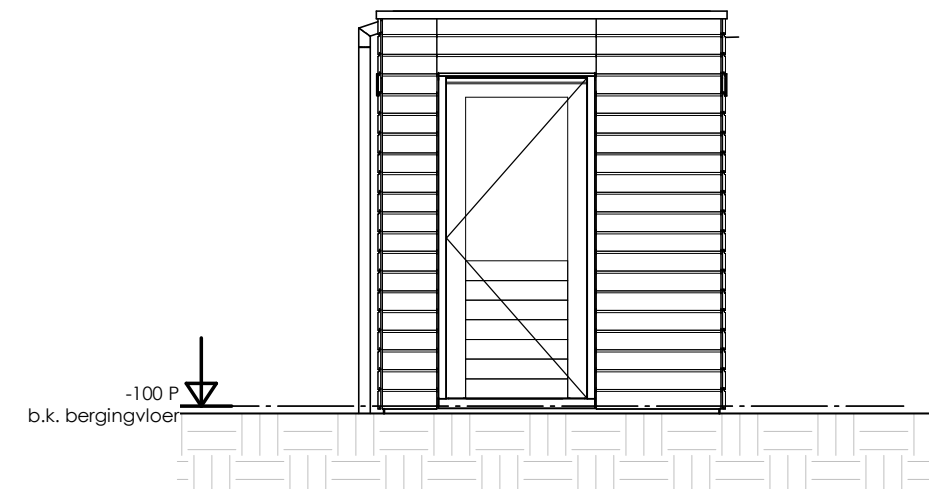

Bouwnummer 41-44-45-48
Rechterzij aanzicht



Bouwnummer 41-44-45-48
Achter aanzicht

Bouwnummer 40-43-46-49

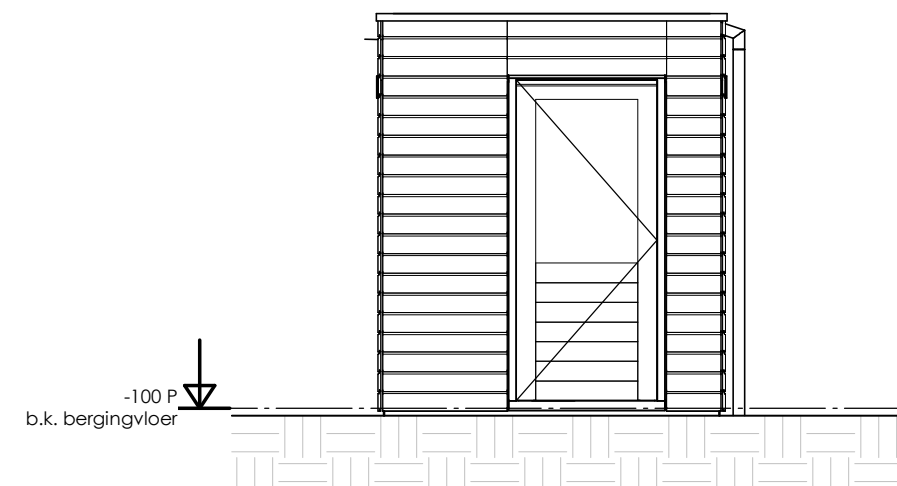

Bouwnummer 40-43-46-49
Linkerzij aanzicht

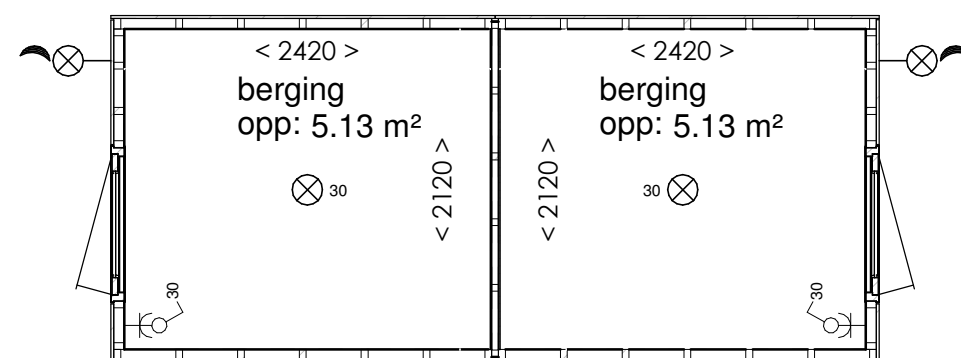

Bouwnummer 40-43-46-49 hwa Bouwnummer 41-44-45-48

Plattegrond

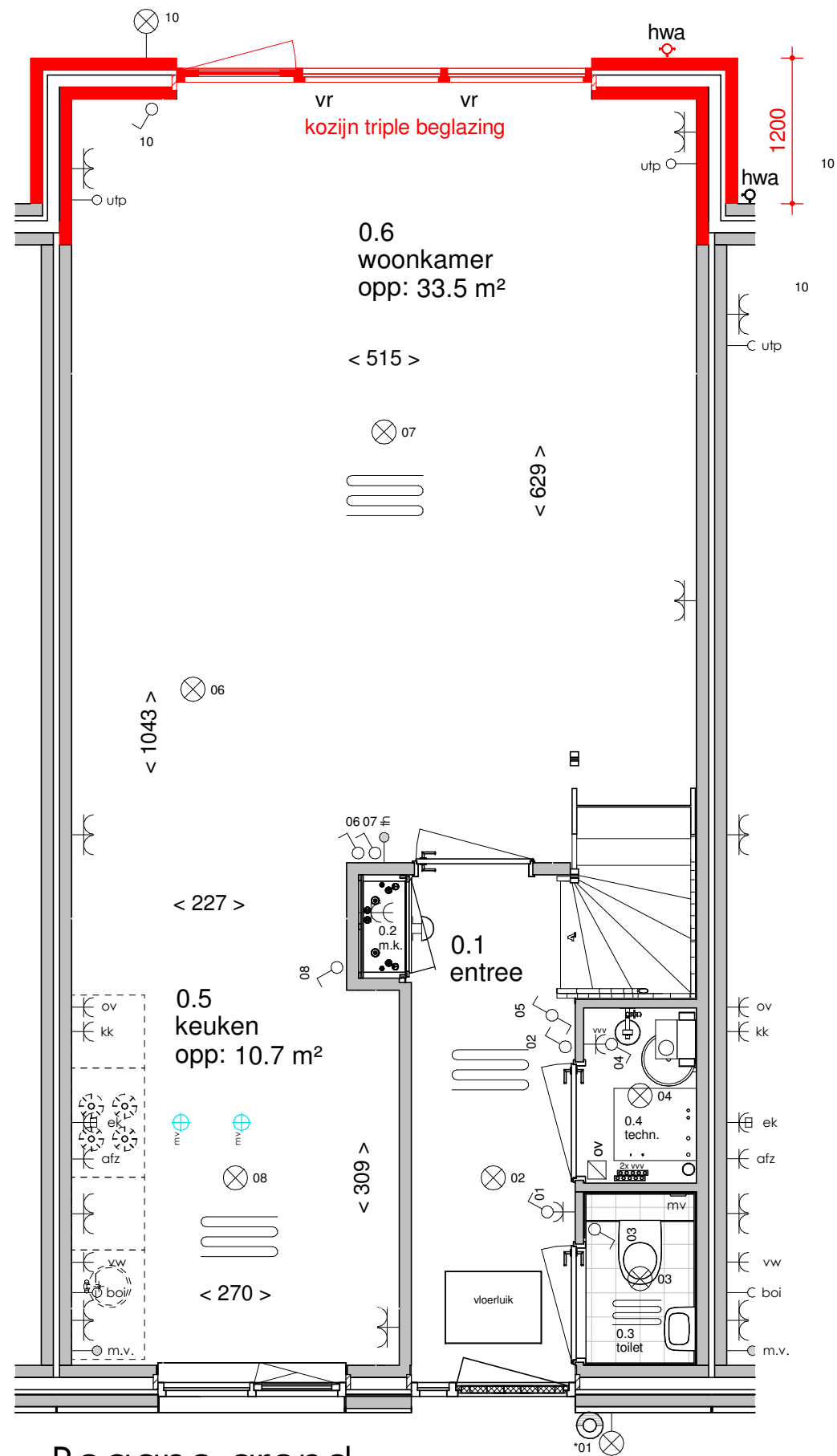

Begane grond

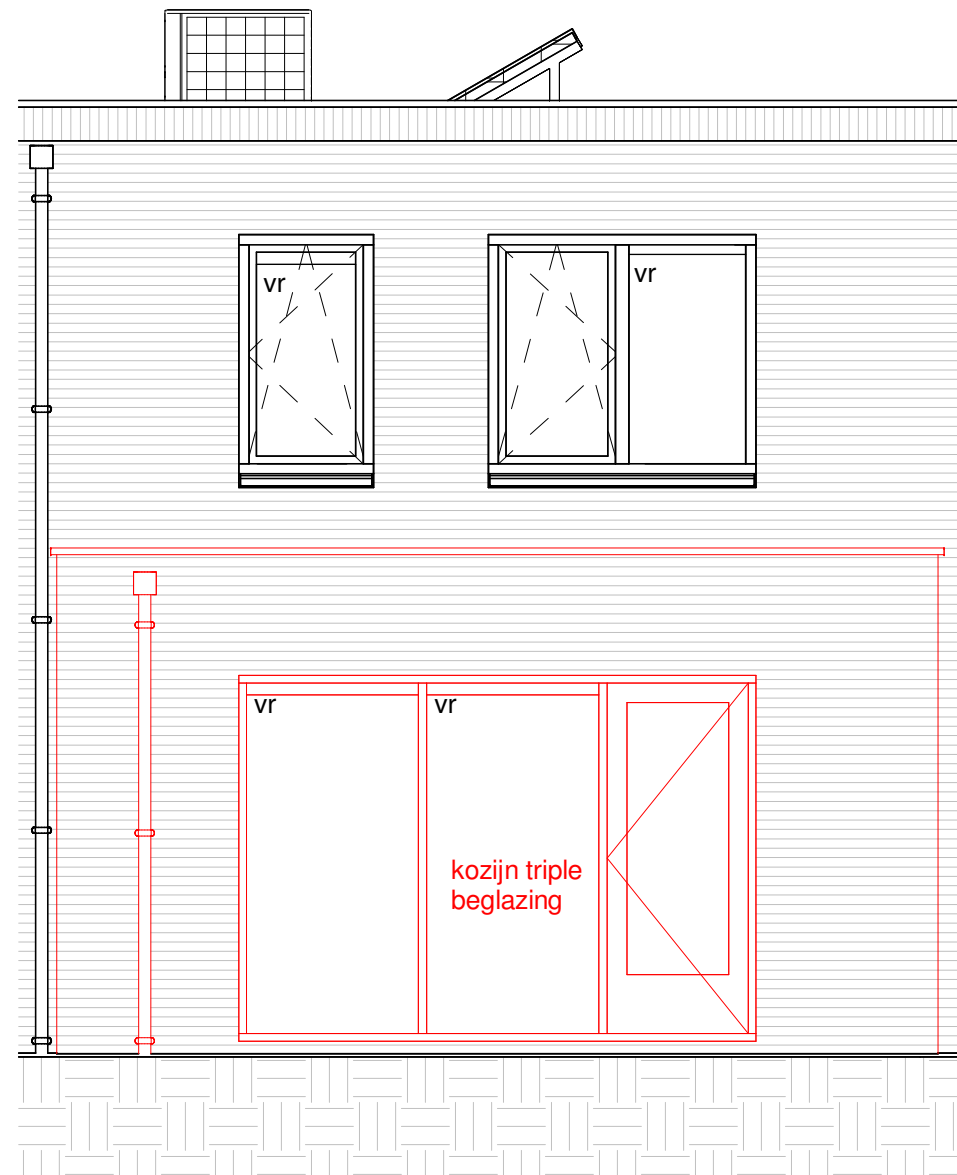

Achteraanzicht

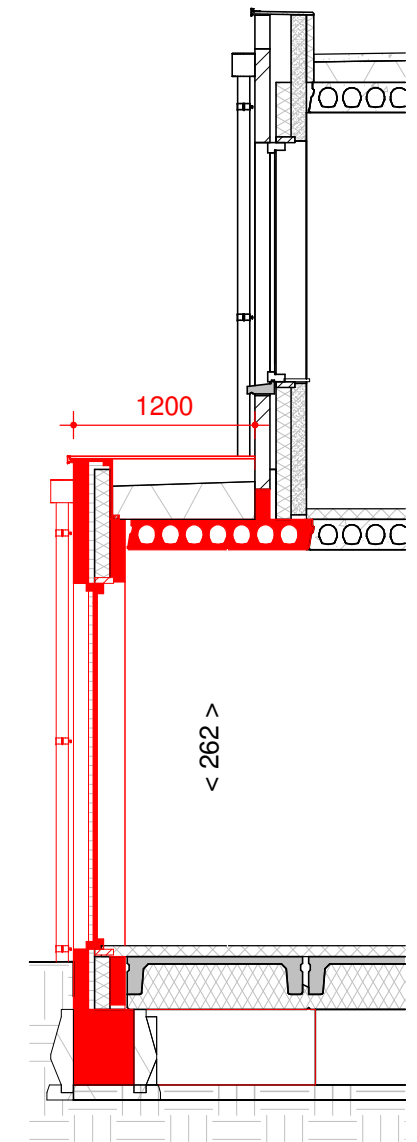

Doorsnede

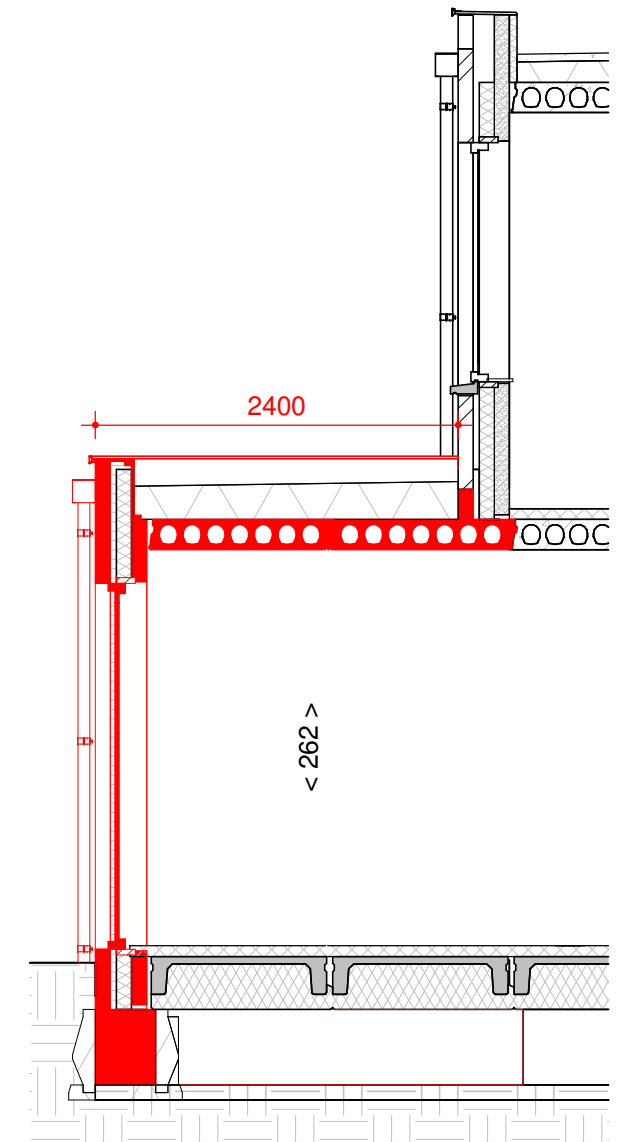
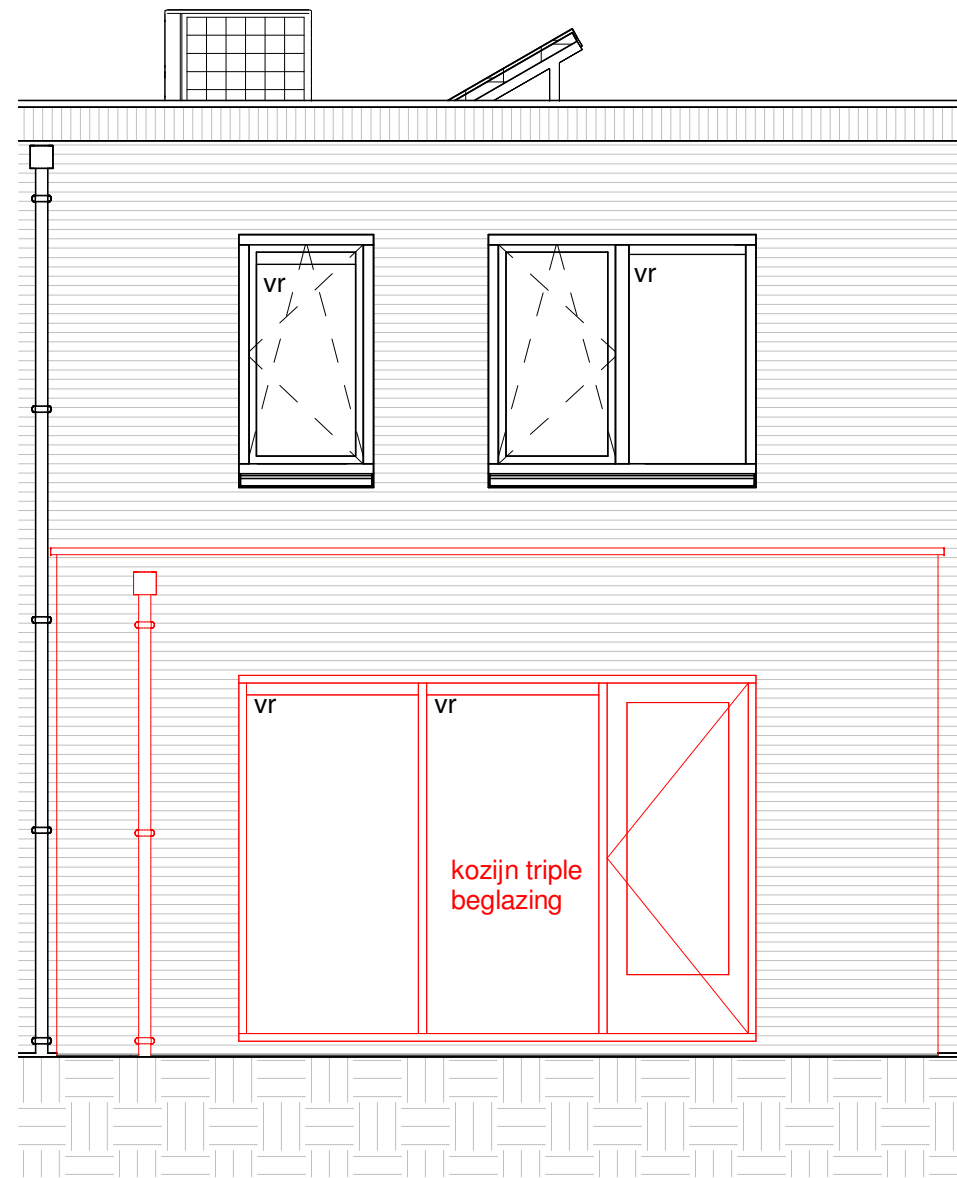
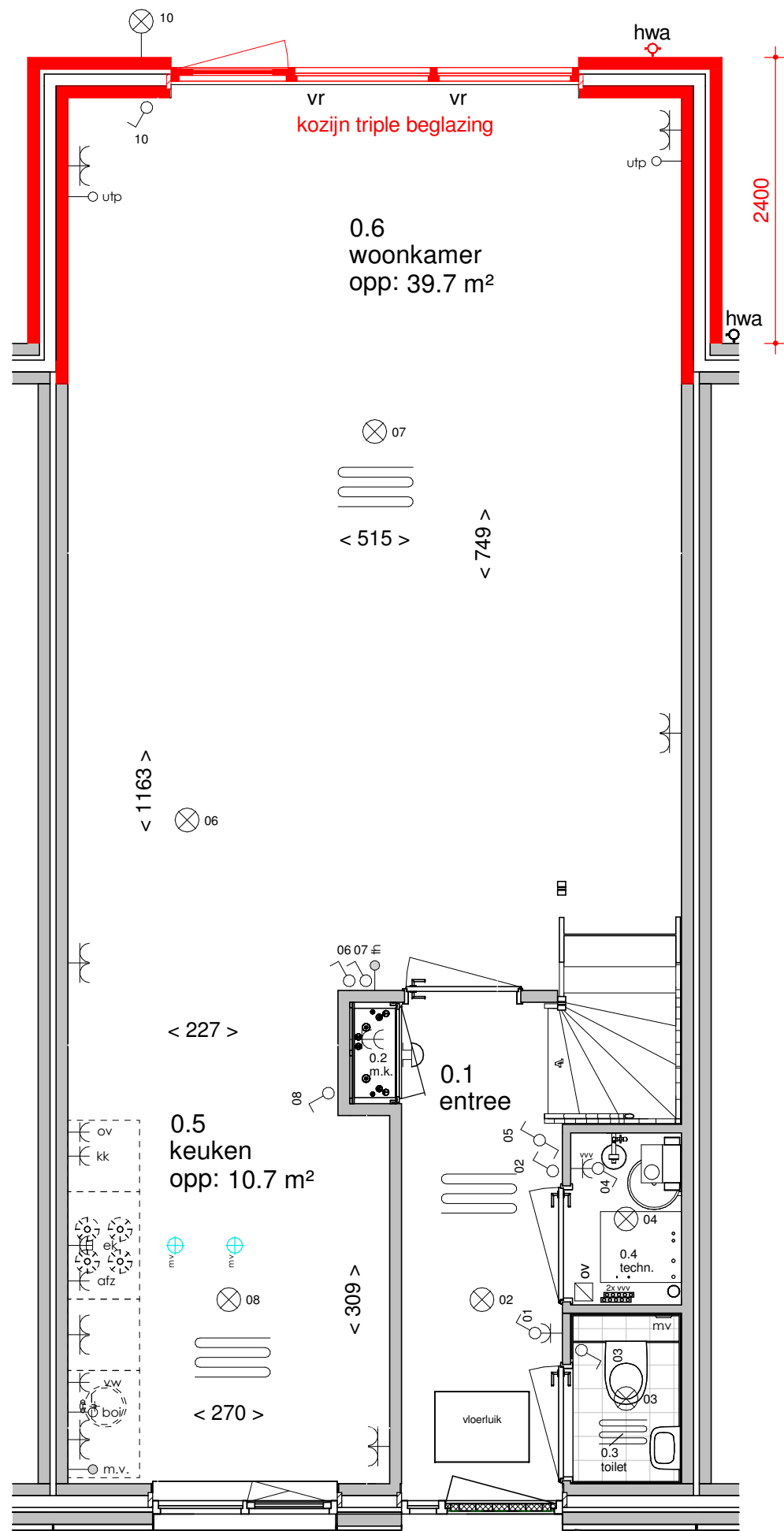

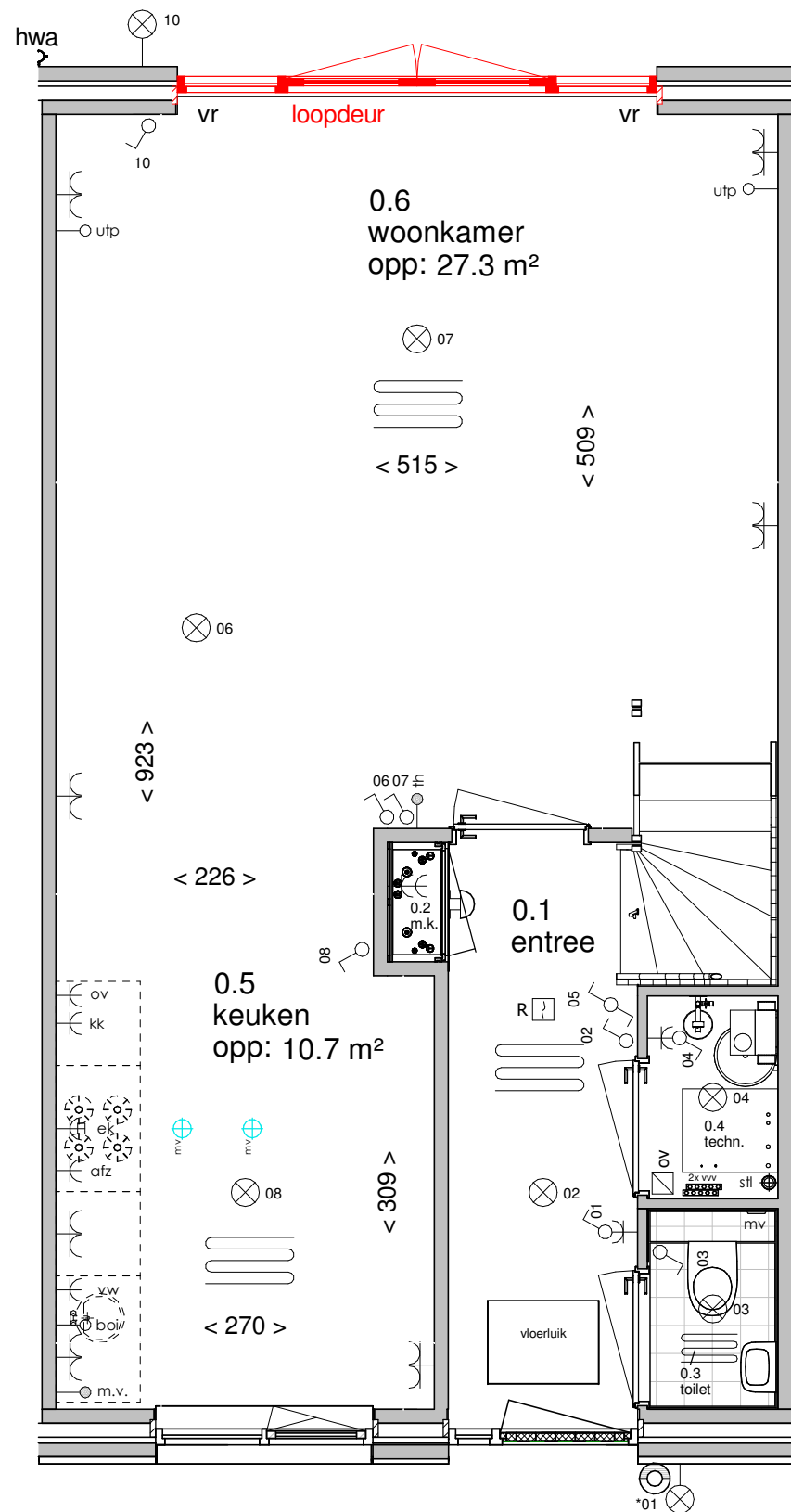

Begane grond

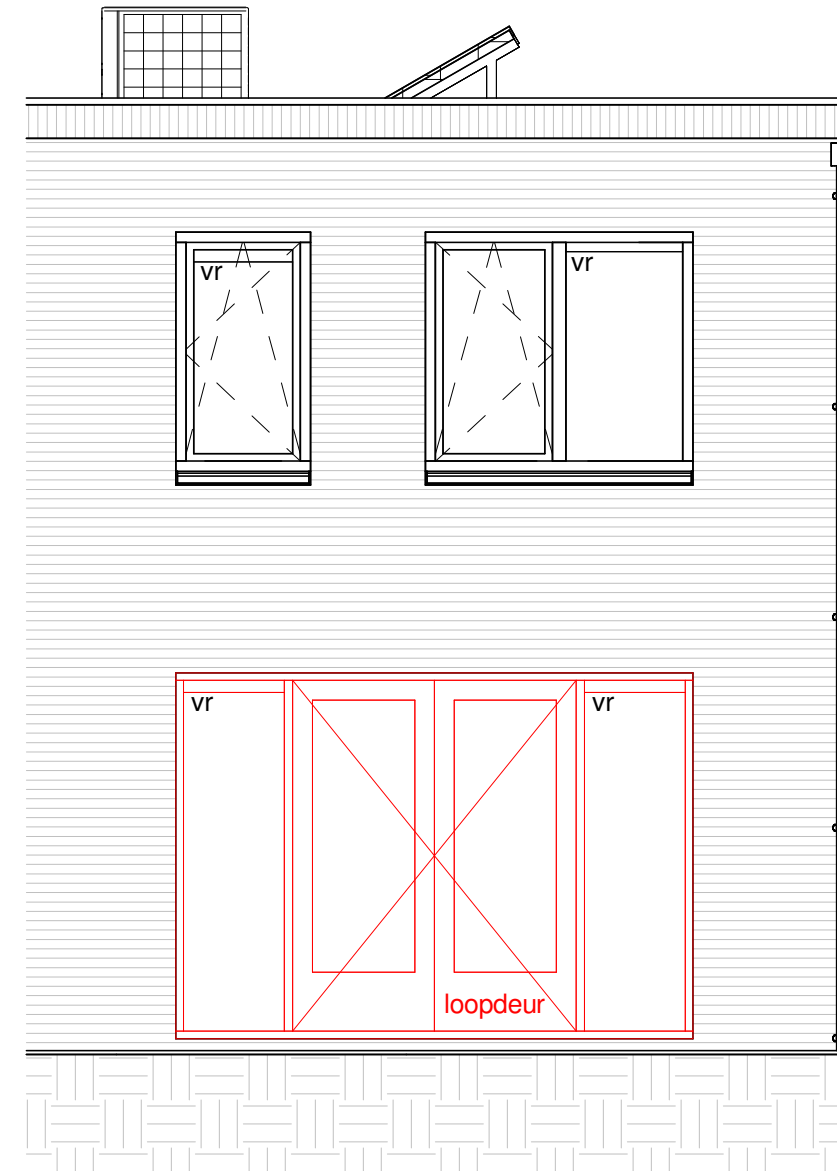

Achteraanzicht

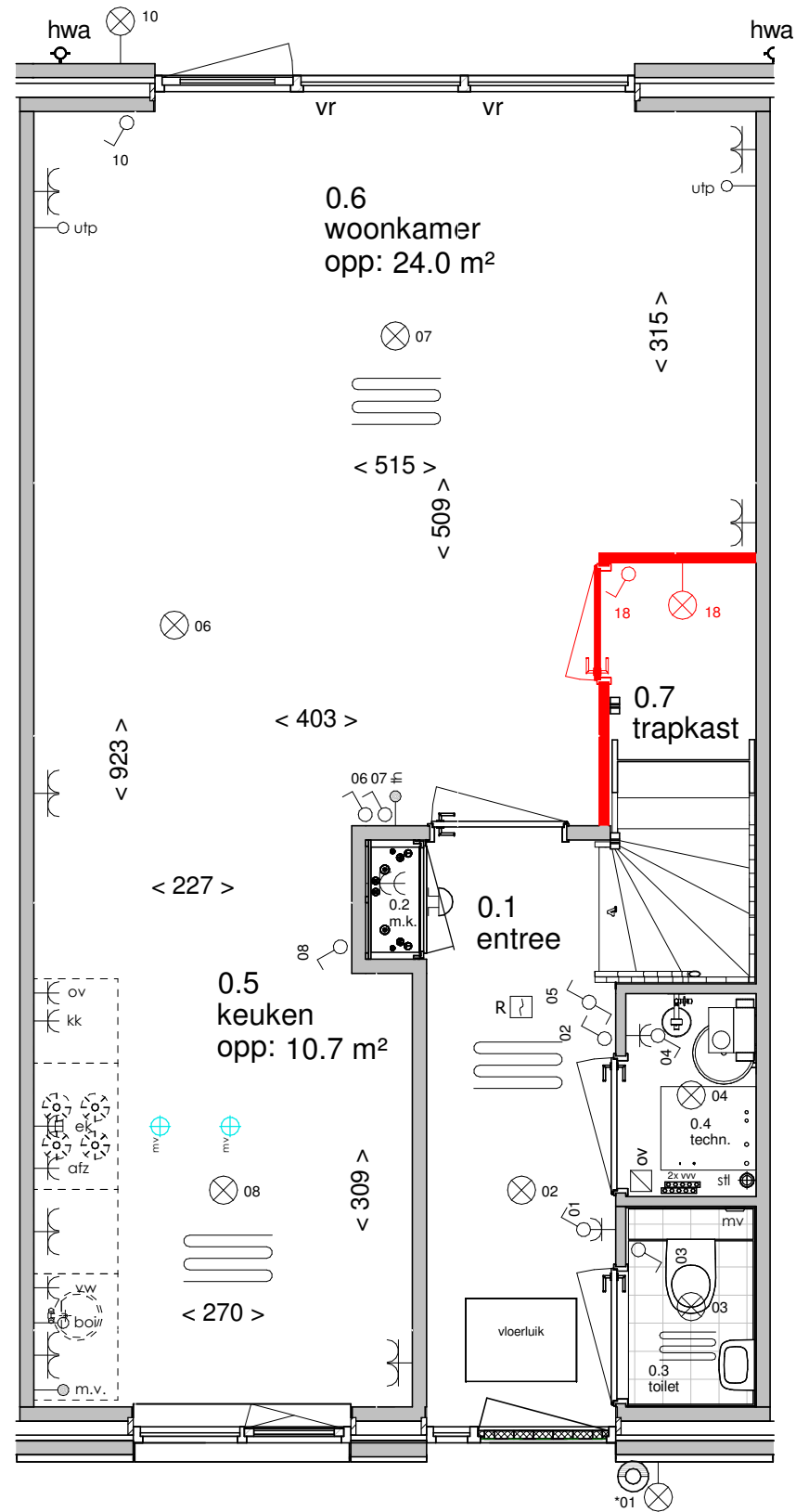

Begane grond

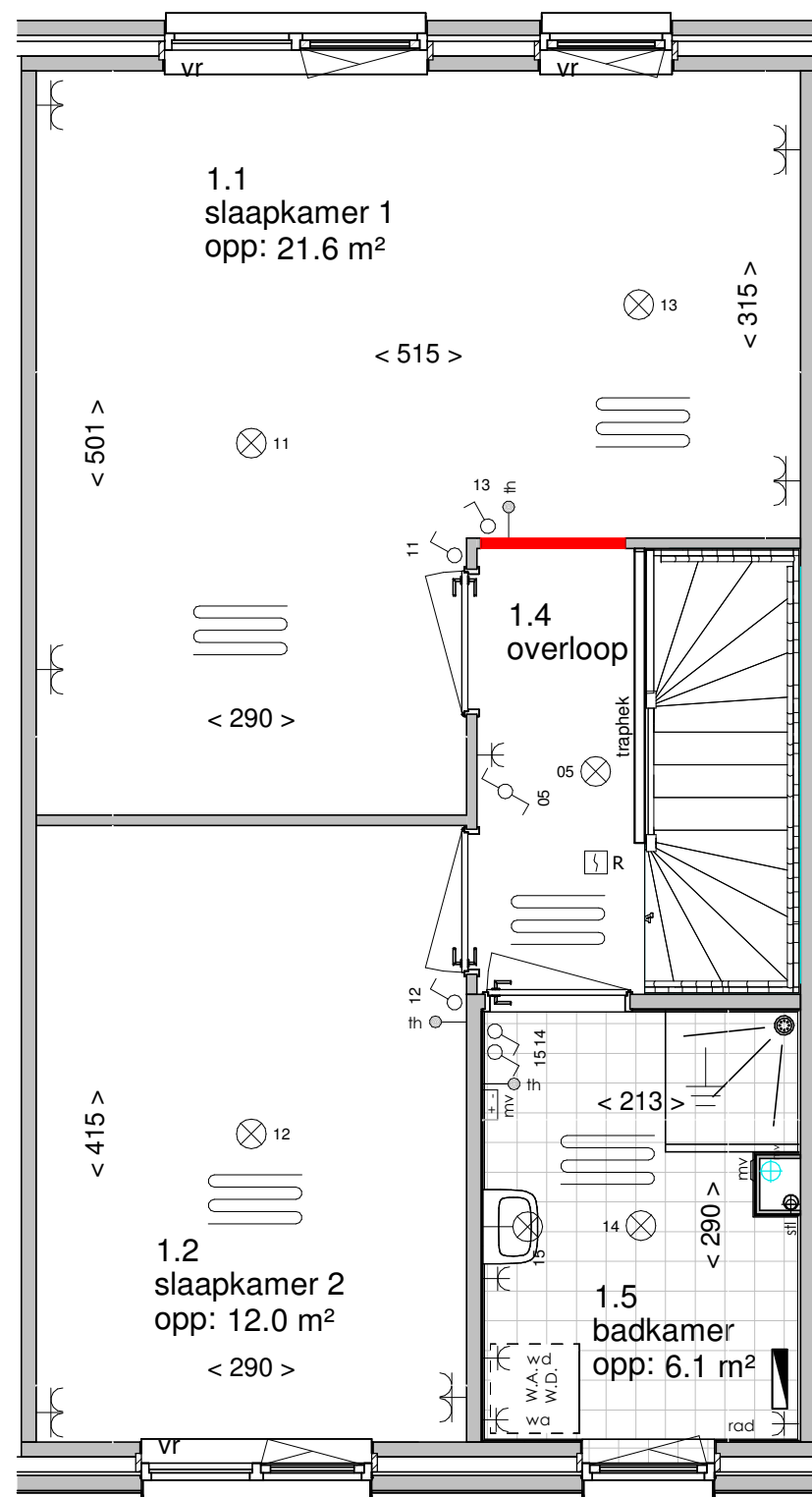

Eerste verdieping

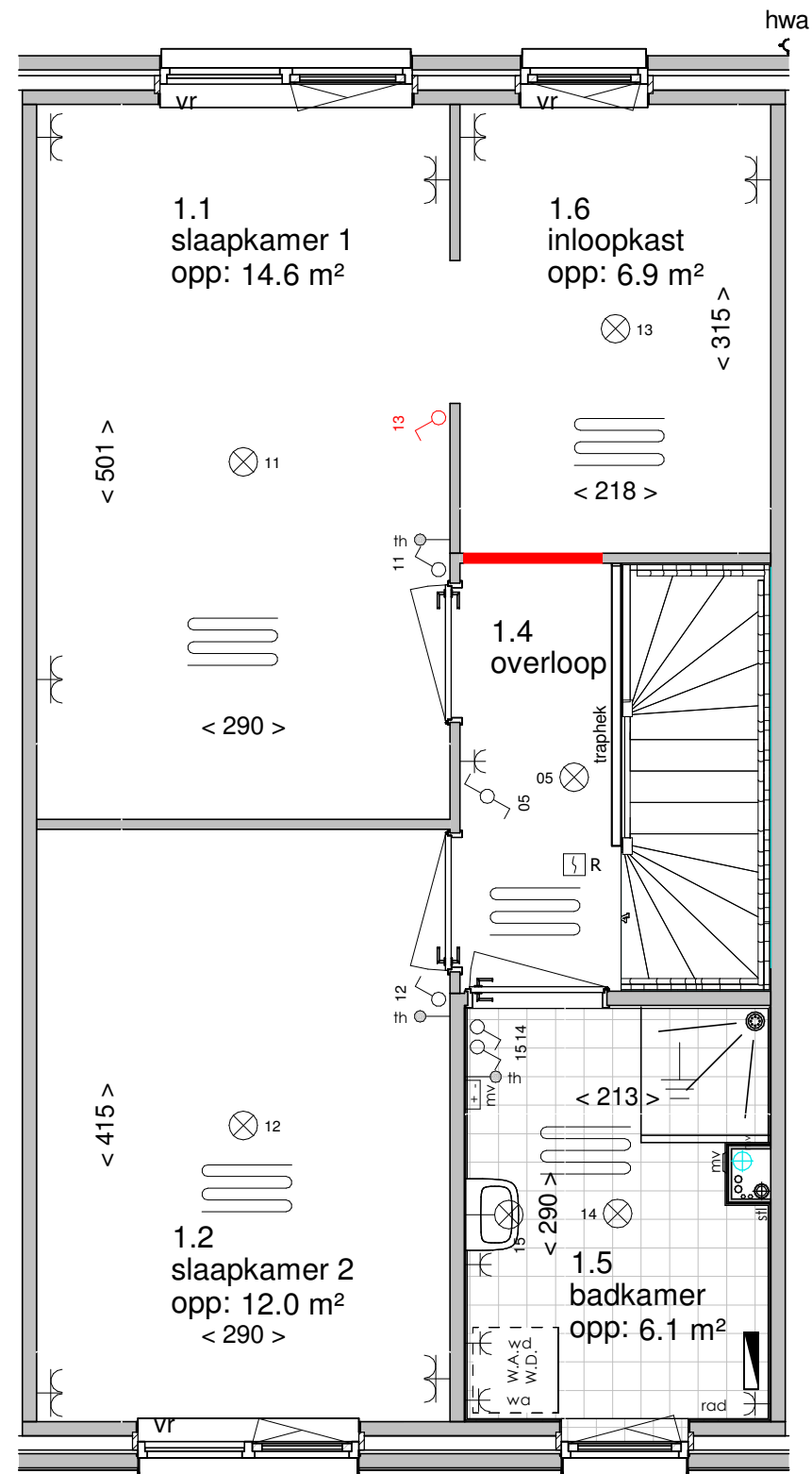

Eerste verdieping

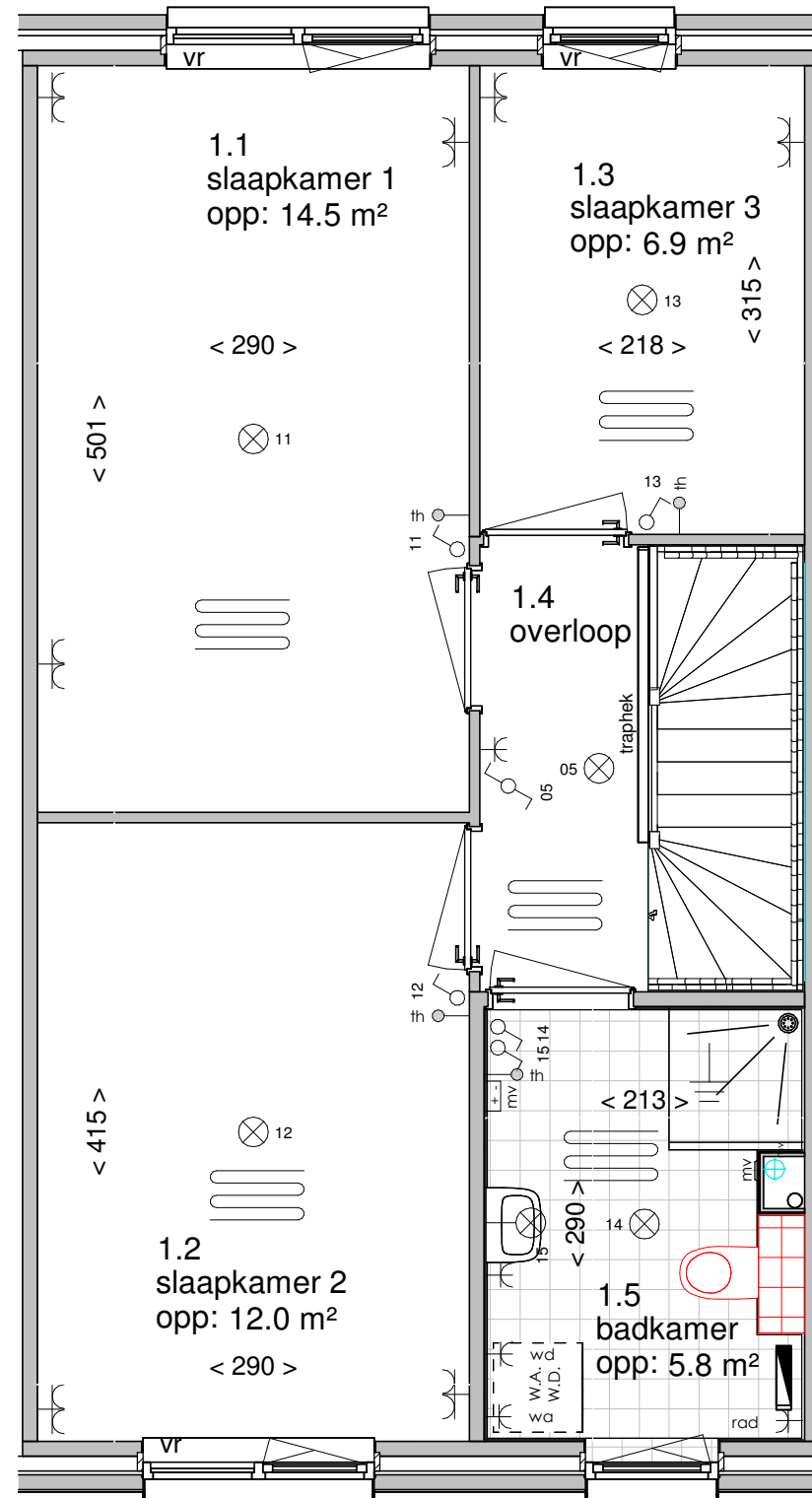

Eerste verdieping

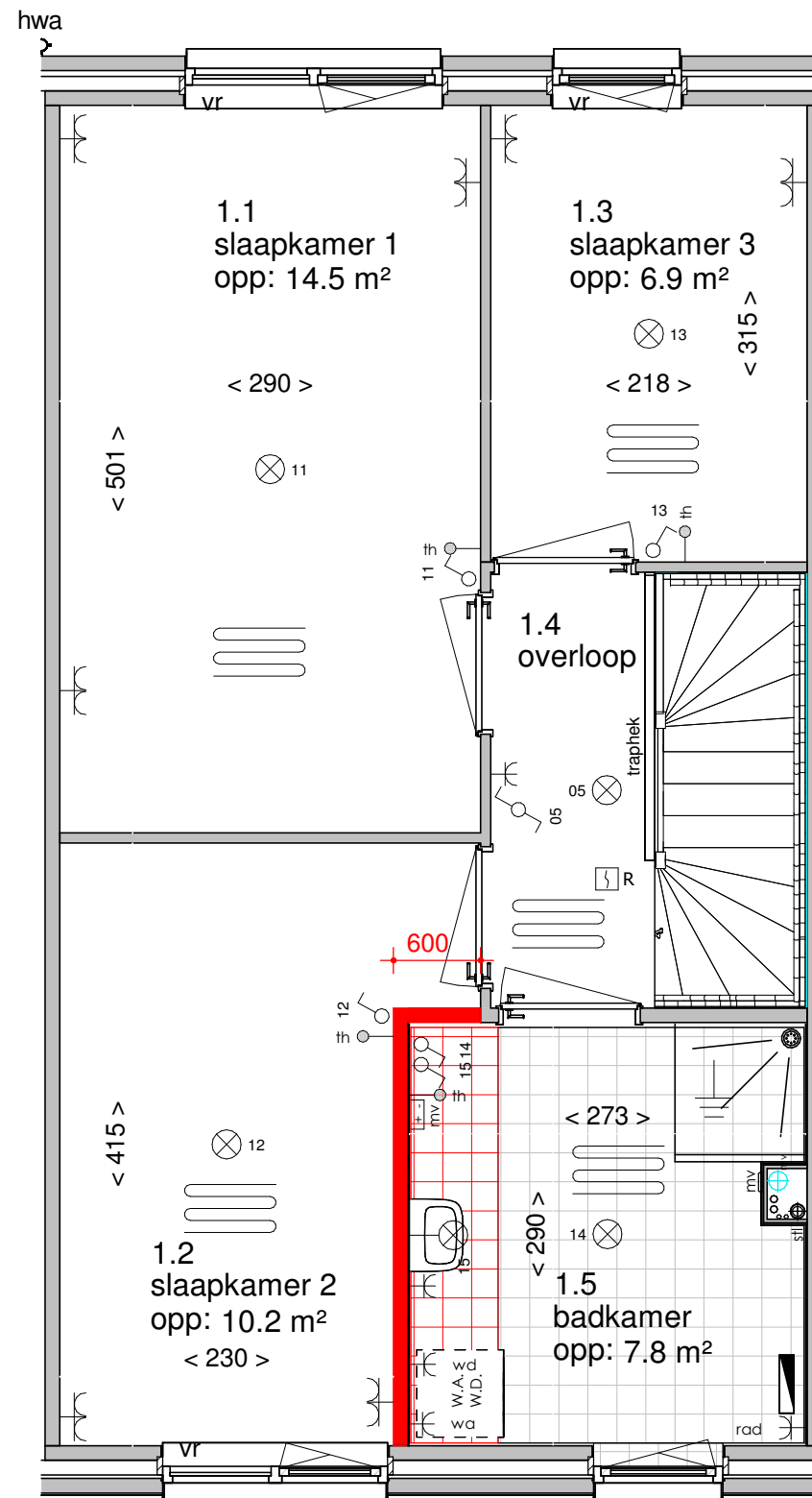

Eerste verdieping